

DESCRIPTION

This class AB LDMOS module is designed for both military and commercial applications. It is capable of supporting any signal type and modulation format, including but not limited to 3-4G telecom, WLAN, OFDM, DVB, and CW/AM/FM. The latest device technologies and design methods are employed to offer high power density, efficiency, and linearity in a small, lightweight package.



Features

Manual or Automatic Tx/Rx Switching Available
Over-Temperature Protection

Temp. Monitor Output
Amplifier Status Output

Specifications subject to change without notice. Typical performance at +28VDC at 25°C in a 50Ω system

TX SPECIFICATIONS(PER CHANNEL)				
PARAMETER	MIN	TYP.	MAX	UNIT
Operating Frequency	2200		2500	MHz
Gain		25.0		dB
Gain Flatness		1.0		± dB
Input Return Loss	-10	-14		dB
Operating Voltage	+12	+28	+30	VDC
Tx / Rx Switching Time		1.0	2.0	uS
RX SPECIFICATIONS(PER CHANNEL)				
PARAMETER	MIN	TYP.	MAX	UNIT
P1dB Power Output		+5.0		dBm
Gain		12.0		dB
Gain Flatness			1.0	± dB
Noise Figure		2.5		dB
Input Return Loss	-10			dB
Current Draw		250.0		mA

MECHANICAL			
PARAMETER	VALUE		UNIT
Dimensions (L x W x H)	3.4 x 2.6 x 0.65		in
RF Connectors (Input / Output)	SMP-M / SMP-M		--
DC / Control Connector	Rectangular Locking		--
Cooling	Baseplate Conduction - Optional Heatsink Available		--
Mounting	4-40 Thru Holes		--
Weight	5		oz.
ENVIRONMENTAL / PROTECTIONS			
PARAMETER	MIN	MAX	UNIT
Operating Temperature (Housing Temp.)	-20	+85	°C
Humidity Range	0-95		%
Altitude	0-30,000		ft.
Shock / Vibration	MIL-STD-810 and equivalents		--
Max RF Input	23		dBm
PA Baseplate Shutoff Temperature	+85		°C

INPUT/OUTPUT PINS		
AMPLIFIER CONNECTOR TYPE:		10 POSITION HARWIN RECTANGULAR
TRIAD CABLE PART NUMBER:		CBL79
PIN LABEL	NAME	DESCRIPTION
1	Status	Operational State - TTL High = Amp Active, TTL Low = Amp Fault
2	TEMP	Temp Monitor: Temp in DegC = (Vout - 0.5V) * 100
3	Tx/Rx	TTL High = Transmit Mode, TTL Low = Receive Mode
5,7,9	+VDC	Supply Voltage - Range Specified in Datasheet
6,8,10	GND	Ground



802-11G (20 MHz BW) DATA RATE VS. OUTPUT POWER(PER CHANNEL)			
OFDM MODULATION	DATA RATE	POUT (W) MIN.	EVM
64QAM	54 Mbps	4	≤ -27 dB
16QAM	36 Mbps	6	≤ -21 dB
QPSK	12 Mbps	10	≤ -15 dB
BPSK	9 Mbps	13	≤ -7 dB

See our [application note](#) that describes how this table was calculated and provides notes on in-system performance

High-Level Block Diagram

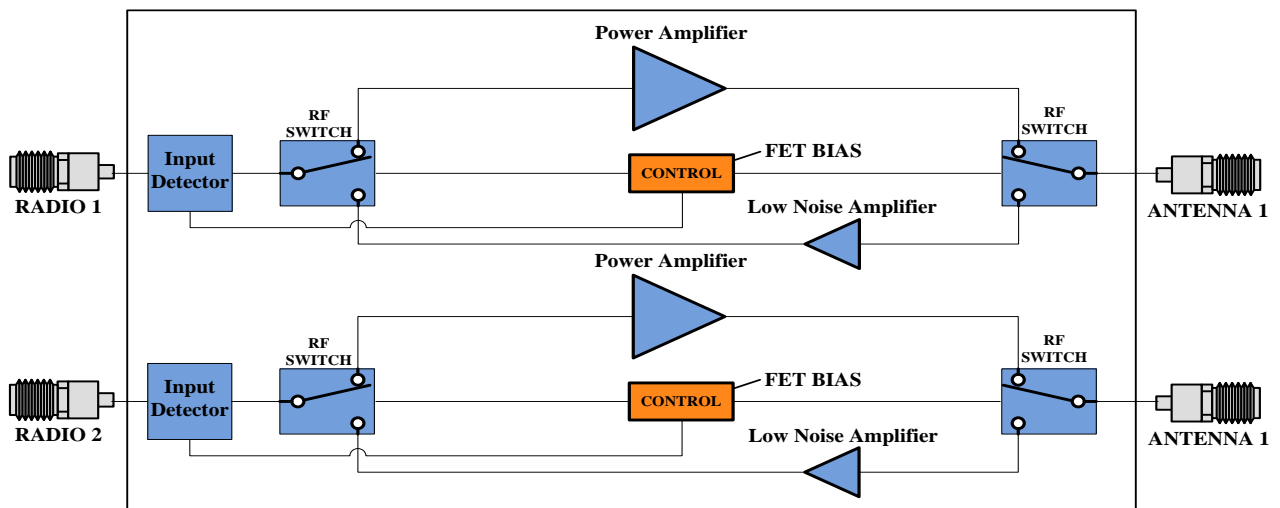

REVISIONS			
REV	DESCRIPTION	DATE	APPROVED
0	Initial Release	6/20/19	AC

.000 .250 .400 .650

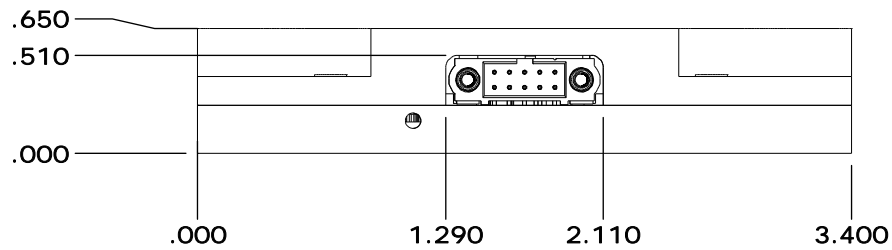
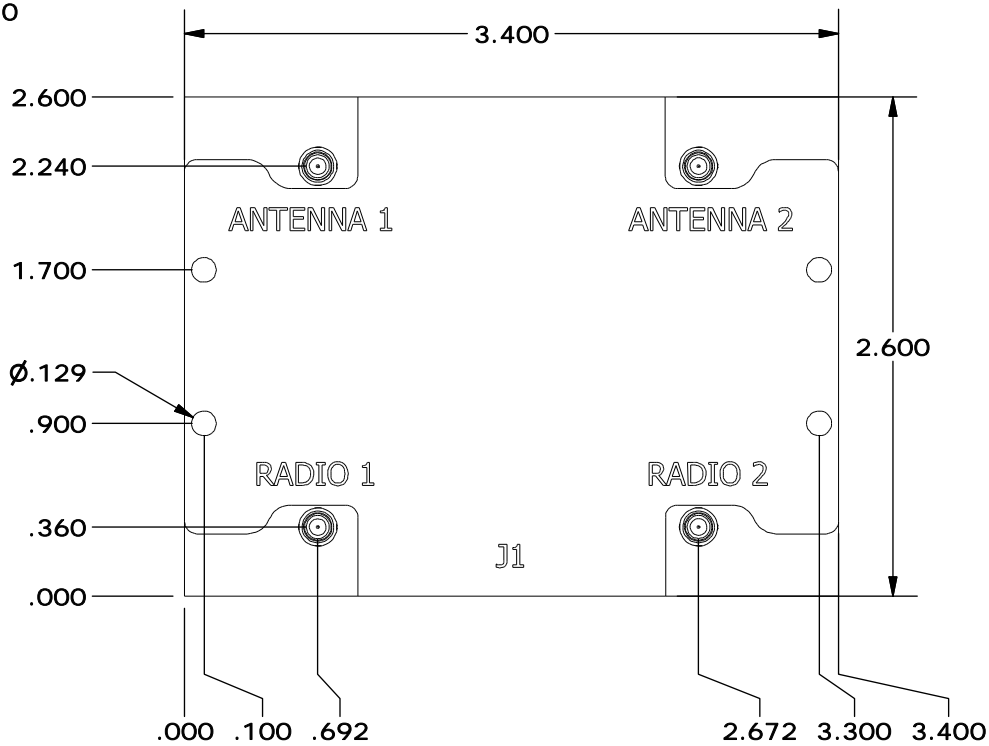

DRAWN	ankur	6/20/2019
DESIGNED	ankur	6/3/2019
CHECKED		
ENG APPROVED		
MFG APPROVED		



11 HARTS LANE SUITE 1
EAST BRUNSWICK, NJ 08816
855- 558- 1001

DIMENSIONS ARE IN INCHES
UNLESS SPECIFIED OTHERWISE
TOLERANCES
DECIMALS FRACTIONS ANGLES
XX ±.01 ± 1/32 ± 2°
.XXX ±.005

SIZE	DWG NO.	REV
A	TTRM2005D	
SCALE: NONE	CAGE CODE 67DZ3	SHEET 1 OF 1



CONNECTOR GROUP : 79
CONNECTOR TYPE : 10 POSITION HARWIN RECTANGULAR
CONNECTOR P/N : M80-4611005
CABLE P/N : CBL79

DC / CONTROL PINS						
PIN LABEL	NAME	DESCRIPTION	COLOR	GAUGE	LENGTH	LABEL
1	Status	STATUS	Green	22-24 AWG	12	STATUS
2	TEMP	TEMP	Orange	22-24 AWG	12	TEMP
3	Tx/Rx	TTL High = Enable, TTL Low or No Connection = Disable	Blue	22-24 AWG	12	I/O
5,7,9	+VDC	Supply Voltage - Range Specified in Datasheet	Red	22-24 AWG	12	+VDC
6,8,10	GND	Ground	Black	22-24 AWG	12	GND

