

DESCRIPTION

This class AB GaN module is designed for both military and commercial applications. It is capable of supporting any signal type and modulation format, including but not limited to 3-4G telecom, WLAN, OFDM, DVB, and CW/AM/FM. The latest device technologies and design methods are employed to offer high power density, efficiency, and linearity in a small, lightweight package.



FEATURES

- Manual or Automatic Tx/Rx Switching Available
- Over-Temperature Protection
- Over / Under Voltage Protection
- Temp. Monitor Output

Specifications subject to change without notice. Typical performance at VDC at 25°C in a 50Ω system

TX SPECIFICATIONS (PER CHANNEL)				
PARAMETER	MIN	TYP.	MAX	UNIT
Operating Frequency	4400		5000	MHz
PSat Power Output		+44.0		dBm
Gain		25.0		dB
Gain Flatness		1.0		± dB
Input Return Loss	-14			dB
Operating Voltage	+12		+28	VDC
Tx / Rx Switching Time		1.0	2.0	uS

RX SPECIFICATIONS (PER CHANNEL)				
PARAMETER	MIN	TYP.	MAX	UNIT
P1dB Power Output		+5.0		dBm
Gain		12.0		dB
Gain Flatness			1.0	± dB
Noise Figure		2.5		dB
OIP3		+15.0		dBm
Input Return Loss	-10			dB
Current Draw		250.0		mA

MECHANICAL		
PARAMETER	VALUE	UNIT
Dimensions (L x W x H)	6 x 4.77 x 2.5	in
RF Connectors (Input / Output)	TNC-F / TNC-F	--
DC / Control Connector	Circular Locking	--
Cooling	Baseplate Conduction - Optional Heatsink Available	--
Mounting	#8 Slots	--
Weight	40	oz.

ENVIRONMENTAL / PROTECTIONS			
PARAMETER	MIN	MAX	UNIT
Operating Temp. (Housing Temp.)	-40	+85	°C
Humidity Range	0-100		%
Altitude	0-30,000		ft.
Shock / Vibration	MIL-STD-810 and equivalents		--
Max RF Input (Per Channel)	+20		dBm
PA Baseplate Shutoff Temperature	+85		°C

DC / CONTROL PINS		
AMPLIFIER CONNECTOR TYPE:		14 PIN CIRCULAR LOCKING
TRIAD CABLE PART NUMBER:		CBL68
PIN LABEL	NAME	DESCRIPTION
B, E, F	+VDC	Supply Voltage - Range Specified in Datasheet
L,K,P	GND	Ground
A	STATUS	BDA Status - TTL High = Normal Operation, TTL Low = Error Condition
C	Tx/Rx	TTL Control Line for Manual TX/RX Control - TTL LOW: RX Mode, TTL HIGH: TX Mode
J	STATE	BDA Operational State - TTL High = Tx Amp Active, TTL Low = Rx Amp Active
M	TEMP	Temp Monitor: Temp in DegC = (Vout - 0.5V) * 100
R	SGND	Signal Ground
D,H,N	NC	No Connection



802-11G (20 MHz BW) DATA RATE VS. OUTPUT POWER (PER CHANNEL)			
OFDM MODULATION	DATA RATE	POUT (W) MIN.	EVM
64QAM	54 Mbps	5	≤ -27 dB
16QAM	36 Mbps	8	≤ -21 dB
QPSK	12 Mbps	12	≤ -15 dB
BPSK	9 Mbps	20	≤ -7 dB

See our [application note](#) that describes how this table was calculated and provides notes on in-system performance

High-Level Block Diagram

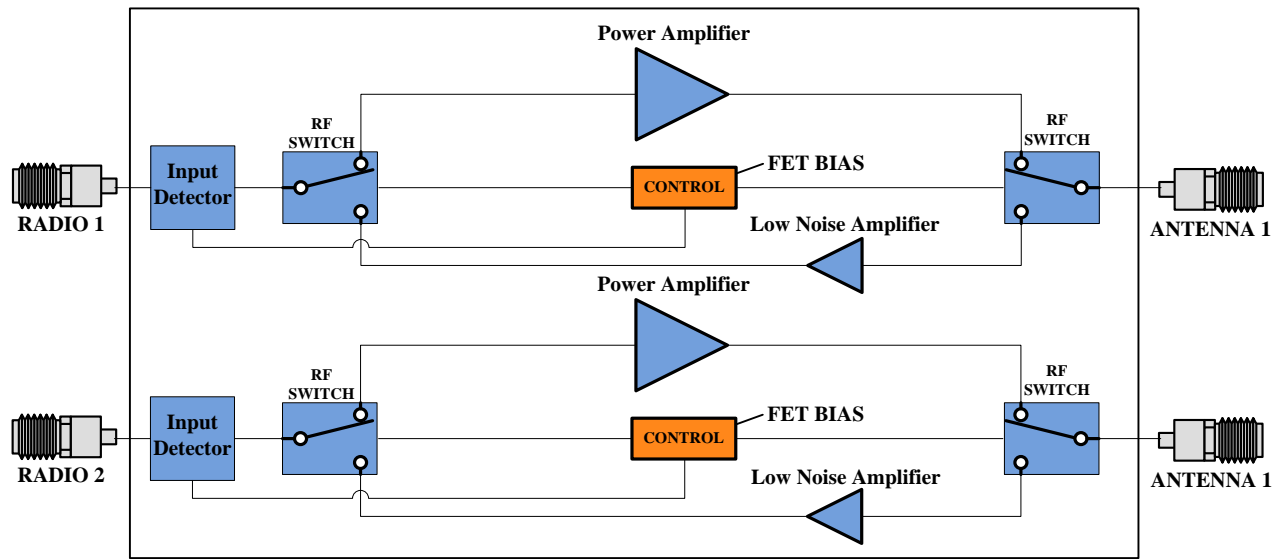

Ordering Guide – Configuration Information		
Model Number	Amplifier Option	Heat Sink Option
TTRMXXXXD	- XXX	- XXX

Amplifier Options		Heat Sink Options	
Suffix	Description	Suffix	Description
D01	Automatic Tx/Rx Switching	(none)	Integrated Heat Sink
D02	Manual Tx/Rx Switching	F	Fan with Integrated Heat Sink
DXX	Custom Amplifier Configuration (issued by Triad upon customer request)		

REVISIONS			
DWG REV	DESCRIPTION	DATE	APPROVED
0	INITIAL RELEASE	10/3/18	DMC

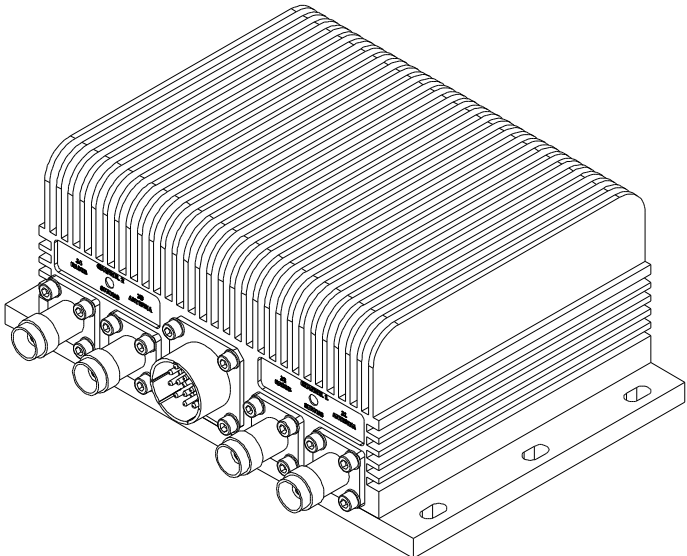
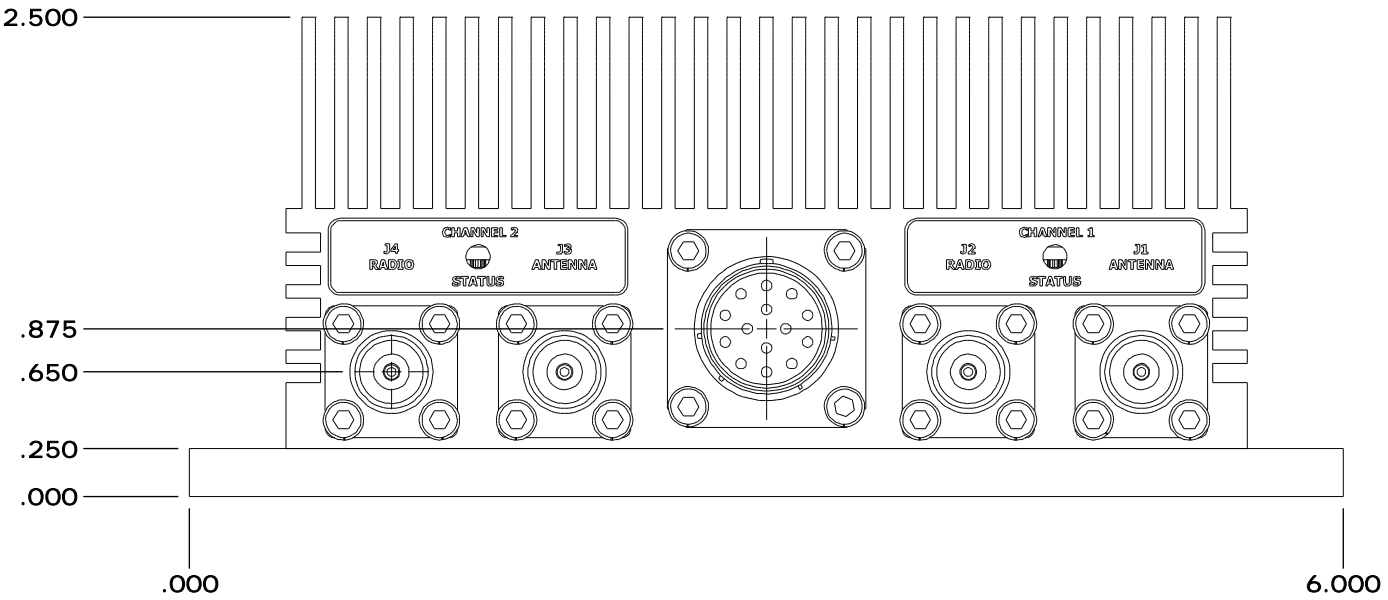

DRAWN	DMC	10/3/2018
DESIGNED	DMC	9/28/2018
CHECKED	DMC	10/3/2018
ENG APPROVED	DMC	10/2/2018
MFG APPROVED	DMC	10/2/2018



11 HARTS LANE SUITE 1
EAST BRUNSWICK, NJ 08816
855- 558- 1001

HOUSING OUTLINE DRAWING 190

DIMENSIONS ARE IN INCHES
UNLESS SPECIFIED OTHERWISE
TOLERANCES
DECIMALS FRACTIONS ANGLES
XX ±.01 ± 1/32 ± 2°
XXX ±.005

SIZE	DWG NO.	DWG REV
A	OL_190	0
SCALE: NONE	CAGE CODE 67DZ3	SHEET 1 OF 2

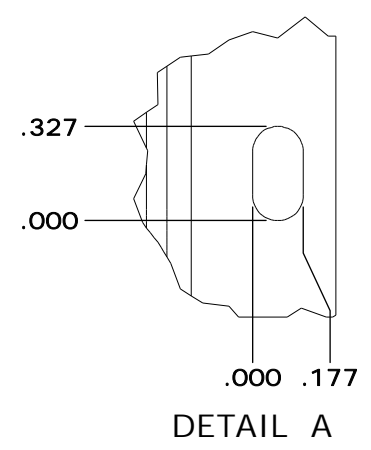
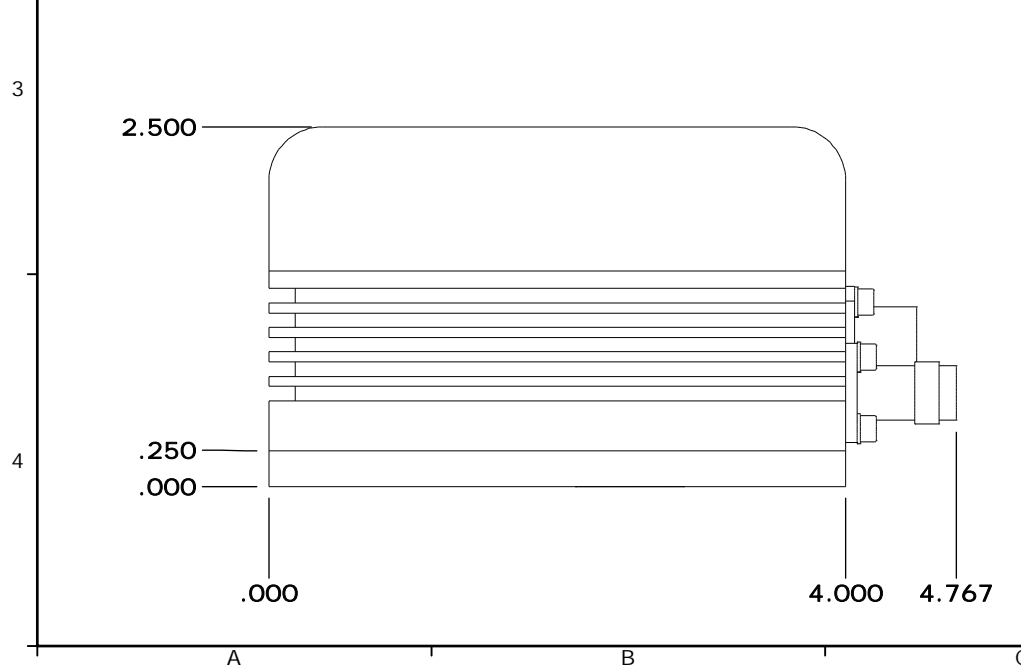
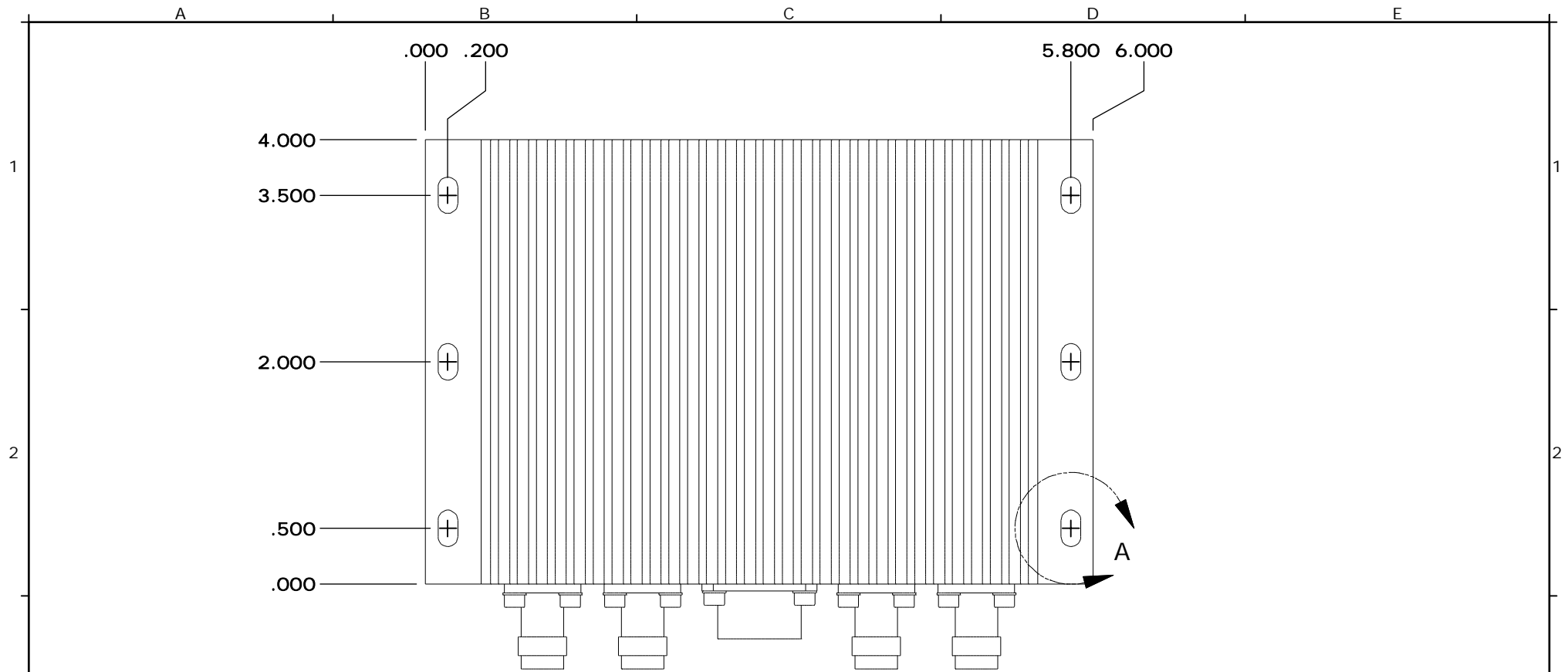

DRAWN	DMC	10/3/2018	HOUSING OUTLINE DRAWING 190		
DESIGNED	DMC	9/28/2018	SIZE	DWG NO.	DWG REV
CHECKED	DMC	10/3/2018	A	OL_190	0
ENG APPROVED	DMC	10/2/2018	SCALE: NONE	CAGE CODE	SHEET 2 OF 2
MFG APPROVED	DMC	10/2/2018		67DZ3	