

### DESCRIPTION

This class AB GaN module is designed for both military and commercial applications. It is capable of supporting any signal type and modulation format, including but not limited to 3-4G telecom, WLAN, OFDM, DVB, and CW/AM/FM. The latest device technologies and design methods are employed to offer high power density, efficiency, and linearity in a small, lightweight package.



### FEATURES

Under Voltage Protection

Over-Temperature Protection

Amplifier Status Output

Temp. Monitor Output

Manual or Automatic Tx/Rx Switching Available

Internal Bypass Relay

Specifications subject to change without notice. Typical performance at +28VDC at 25°C in a 50Ω system

Tx SPECIFICATIONS				
PARAMETER	MIN	TYP.	MAX	UNIT
Operating Frequency	3300		4200	MHz
PSat Power Output		+40.0		dBm
Gain		25.0		dB
Gain Flatness		1.0		± dB
Input Return Loss	-15			dB
Operating Voltage	+10	+28	+30	VDC
Tx / Rx Switching Time		1.0	2.0	uS

Rx SPECIFICATIONS				
PARAMETER	MIN	TYP.	MAX	UNIT
P1dB Power Output		+5.0		dBm
Gain		10.0		dB
Gain Flatness			1.0	± dB
Noise Figure		2.5		dB
OIP3		+15.0		dBm
Input Return Loss	-10			dB
Current Draw		100.0		mA

MECHANICAL		
PARAMETER	VALUE	UNIT
Dimensions (L x W x H)	2.3 x 2.3 x 0.45	in
RF Connectors (Input / Output)	SMP / SMP	--
DC / Control Connector	12 Pin Rectangular Locking	--
Cooling	Baseplate Conduction - Optional Heatsink Available	--
Mounting	4-40 Thru Holes	--
Weight	3	oz.
Weight With Heatsink	0	oz.

ENVIRONMENTAL / PROTECTIONS			
PARAMETER	MIN	MAX	UNIT
Operating Temperature (Housing Temp.)	-40	+85	°C
Humidity Range	0-95		%
Altitude	0-30,000		ft.
Shock / Vibration	MIL-STD-810 and equivalents		--
Max RF Input	17		dBm
PA Baseplate Shutoff Temperature	+85		°C

INPUT/OUTPUT PINS				
<b>AMPLIFIER CONNECTOR TYPE:</b>		<b>12 PIN RECTANGULAR LOCKING</b>		
<b>TRIAD CABLE PART NUMBER:</b>		<b>CBL64</b>		
PIN LABEL	NAME	DESCRIPTION	TYPE	LEVEL
1,3,5	GND	Ground	--	--
2	STATUS 1	BDA Operational State - TTL High = Tx Amp Active, TTL Low = Rx Amp Active	Output	5V TTL
6	TEMP	Temp Monitor: Temp in DegC = (Vout - 0.5V) * 100	Output	Analog
7	STATUS 2	BDA Status - TTL High = Normal Operation, TTL Low = Error Condition	Output	5V TTL
9	BYPASS	Bypass Control: TTL High or Open: Amplifier Mode, GND: Bypass	Input	5V TTL
11	Tx/Rx	Tx/Rx Switching - TTL High = Tx Amp Enabled, TTL = Rx Amp Enabled	Input	5V TTL
8,10,12	VDC	Supply Voltage - Range Specified in Datasheet	Power	--

802-11G (20 MHz BW) DATA RATE VS. OUTPUT POWER			
OFDM MODULATION	DATA RATE	POUT (W) MIN.	EVM
64QAM	54 Mbps	2	≤ -27 dB
16QAM	36 Mbps	4	≤ -21 dB
QPSK	12 Mbps	6	≤ -15 dB
BPSK	9 Mbps	10	≤ -7 dB

See our [application note](#) that describes how this table was calculated and provides notes on in-system performance

### High-Level Block Diagram

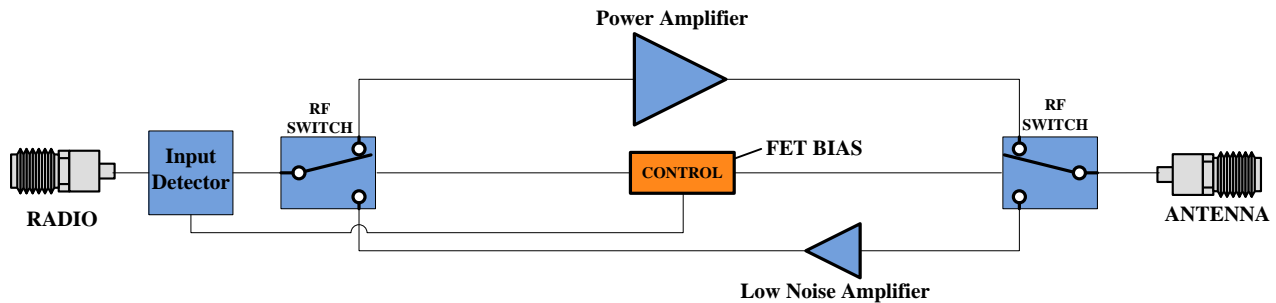

Ordering Guide – Configuration Information		
Model Number	Amplifier Option	Heat Sink Option
<b>TTRMXXXX</b>	<b>- XXX</b>	<b>- XXX</b>

Amplifier Options		Heat Sink Options	
Suffix	Description	Suffix	Description
D01	Automatic Tx/Rx Switching	(none)	No Heat Sink Included
D02	Manual Tx/Rx Switching	HS	Standard Heat Sink
DXX	Custom Amplifier Configuration (issued by Triad upon customer request)	HSF	Heat Sink with Integrated Cooling Fan
		HSX	Custom Heat Sink Configuration

REVISIONS			
REV	DESCRIPTION	DATE	APPROVED
O	INITIAL RELEASE	3/20/19	SC

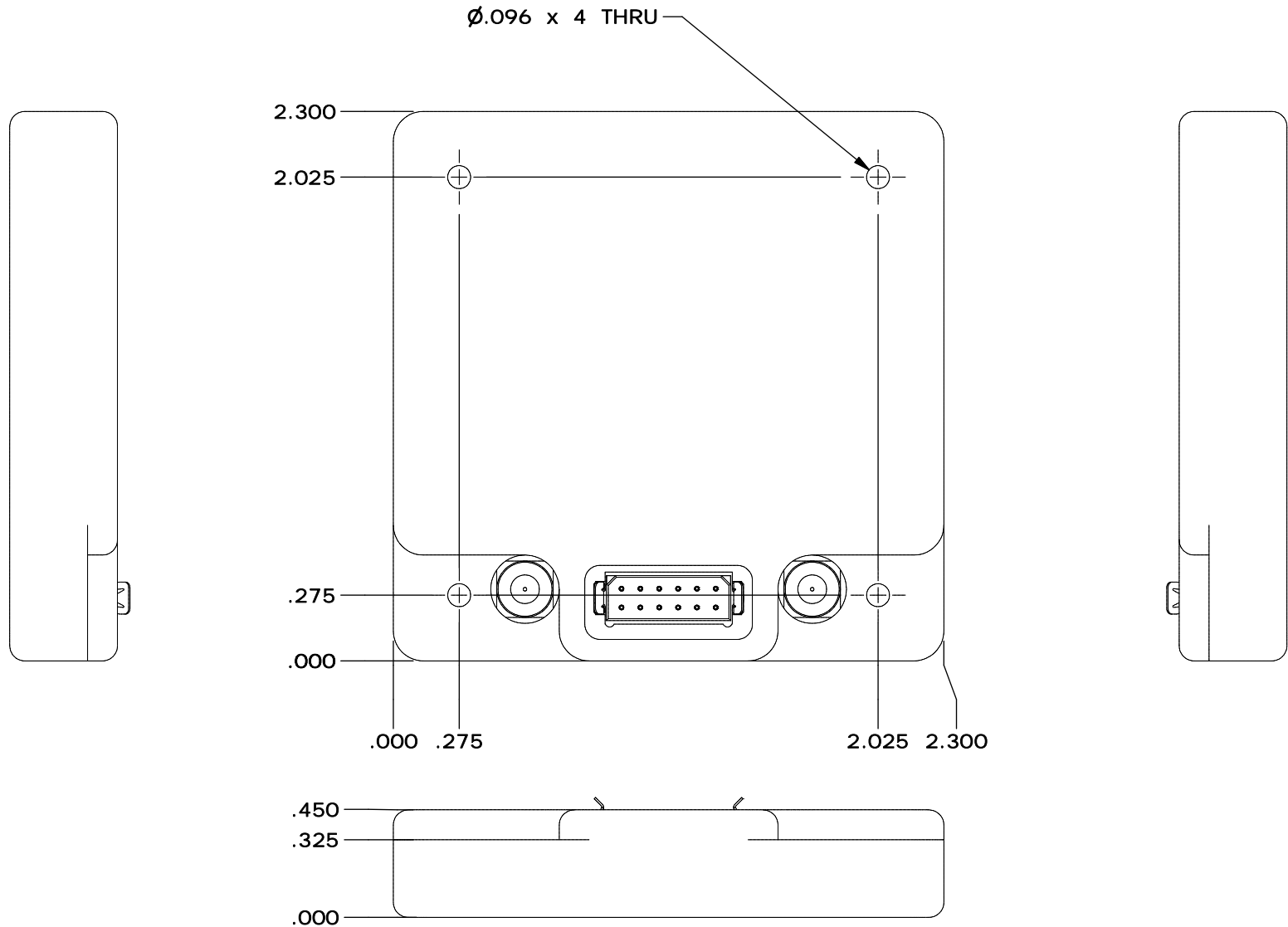

DRAWN	scopp	10/3/2013
DESIGNED	scopp	4/25/2018
CHECKED		
ENG APPROVED		
MFG APPROVED		



11 HARTS LANE SUITE 1  
EAST BRUNSWICK, NJ 08816  
855- 558- 1001

Housing Outline 195

DIMENSIONS ARE IN INCHES  
UNLESS SPECIFIED OTHERWISE  
TOLERANCES  
DECIMALS FRACTIONS ANGLES  
XX ±.01 ± 1/32 ± 2°  
XXX ±.005

SIZE A	DWG NO. OL_195	REV O
SCALE: NONE	CAGE CODE 67DZ3	SHEET 1 OF 1