

DESCRIPTION

This class AB LDMOS module is designed for both military and commercial applications. It is capable of supporting any signal type and modulation format, including but not limited to 3-4G telecom, WLAN, OFDM, DVB, and CW/AM/FM. The latest device technologies and design methods are employed to offer high power density, efficiency, and linearity in a small, lightweight package.



FEATURES

Manual Tx/Rx Switching (TTL)
Optional Heatsink

Temp. Monitor Output

Specifications subject to change without notice. Typical performance at +28VDC at 25°C in a 50Ω system

TX SPECIFICATIONS (PER CHANNEL)				
PARAMETER	MIN	TYP.	MAX	UNIT
Operating Frequency	1350		1390	MHz
PSat Power Output		+44.0		dBm
Gain	24.0	25.0		dB
Gain Flatness		1.0	1.5	± dB
Input Return Loss	-12	-13		dB
Operating Voltage	+27	+28	+30	VDC
Current Draw			5.0	A
Tx / Rx Switching Time		1.0	2.0	uS

RX SPECIFICATIONS (PER CHANNEL)				
PARAMETER	MIN	TYP.	MAX	UNIT
P1dB Power Output		+5.0		dBm
Gain	9.0	11.0		dB
Gain Flatness		0.5	1.3	± dB
Noise Figure		3.0		dB
OIP3		+15.0		dBm
Input Return Loss	-8	-12		dB
Current Draw		120.0		mA

MECHANICAL		
PARAMETER	VALUE	UNIT
Dimensions (L x W x H)	4.1 x 4.226 x 0.818	in
RF Connectors (Input / Output)	SMA-F / SMA-F	--
DC / Control Connector	9 Pin Micro-D	--
Cooling	Baseplate Conduction - Optional Heatsink Available	--
Mounting	4-40 Thru Holes	--
Weight	15	oz.
Weight With Heatsink	33	oz.

ENVIRONMENTAL / PROTECTIONS			
PARAMETER	MIN	MAX	UNIT
Operating Temp. (Housing Temp.)	-40	+85	°C
Humidity Range	0-95		%
Altitude	0-30,000		ft.
Shock / Vibration	MIL-STD-810 and equivalents		--
Max RF Input (Per Channel)	+22		dBm
PA Baseplate Shutoff Temperature	+90		°C

DC / CONTROL PINS		
AMPLIFIER CONNECTOR TYPE:		9 PIN MICRO-D MALE
TRIAD CABLE PART NUMBER:		CBL28
PIN LABEL	NAME	DESCRIPTION
1	+VDC	Supply Voltage - Range Specified in Datasheet
2	+VDC	Supply Voltage - Range Specified in Datasheet
3	NC	No Connection
4	NC	No Connection
5	TEMP	Analog Temperature Sensor Output
6	GND	Ground
7	GND	Ground
8	NC	No Connection
9	TX/RX	3.3V TTL. High = TX, Low (or No Connection) = RX

802-11G (20 MHz BW) DATA RATE VS. OUTPUT POWER (PER CHANNEL)			
OFDM MODULATION	DATA RATE	POUT (W) MIN.	EVM
64QAM	54 Mbps	0	≤ -27 dB
16QAM	36 Mbps	0	≤ -21 dB
QPSK	12 Mbps	0	≤ -15 dB
BPSK	9 Mbps	0	≤ -7 dB

See our [application note](#) that describes how this table was calculated and provides notes on in-system performance

High-Level Block Diagram

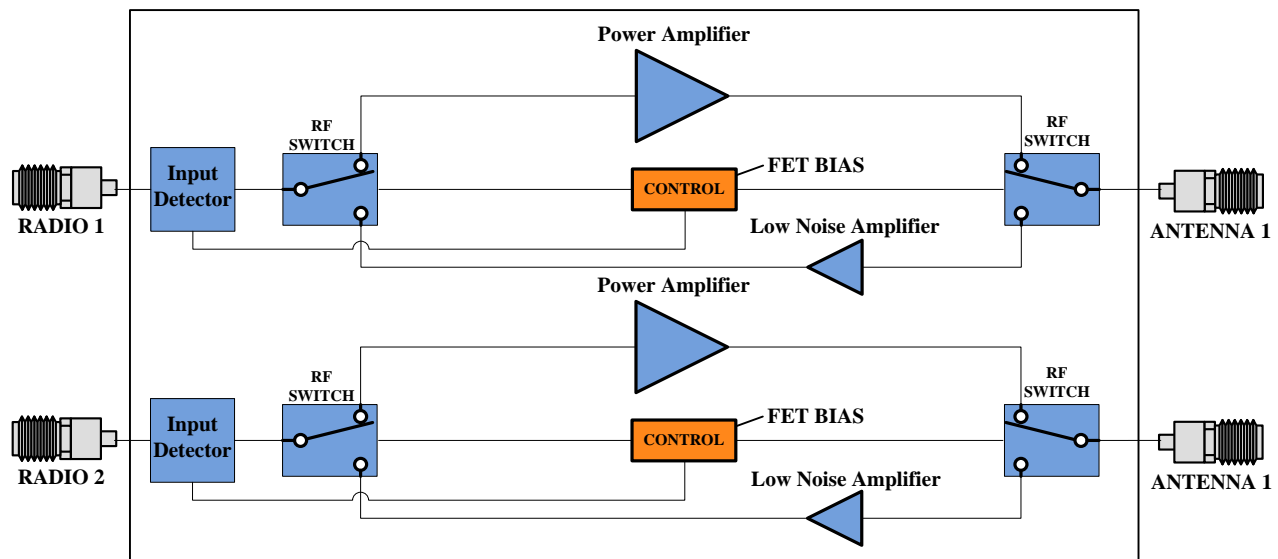

Ordering Guide – Configuration Information		
Model Number	Amplifier Option	Heat Sink Option
TTRMXXXXD	- XXX	- XXX

Amplifier Options		Heat Sink Options	
Suffix	Description	Suffix	Description
D01	Automatic Tx/Rx Switching	(none)	No Heat Sink Included
D02	Manual Tx/Rx Switching	HS	Standard Heat Sink
DXX	Custom Amplifier Configuration (issued by Triad upon customer request)	HSF	Heat Sink with Integrated Cooling Fan
		HSX	Custom Heat Sink Configuration

REVISIONS			
REV	DESCRIPTION	DATE	APPROVED
0	INITIAL RELEASE	4/21/14	DMC

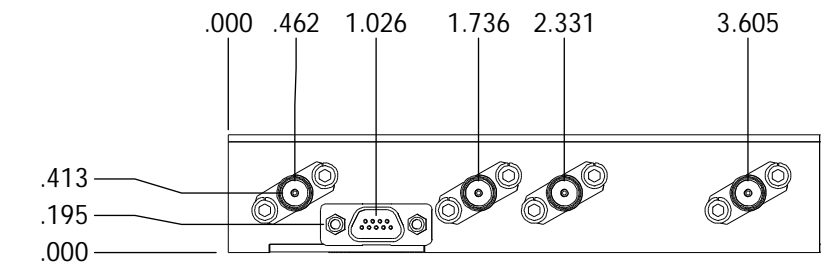
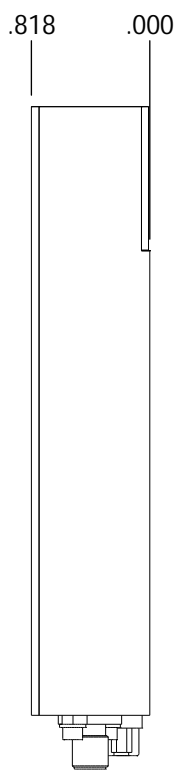
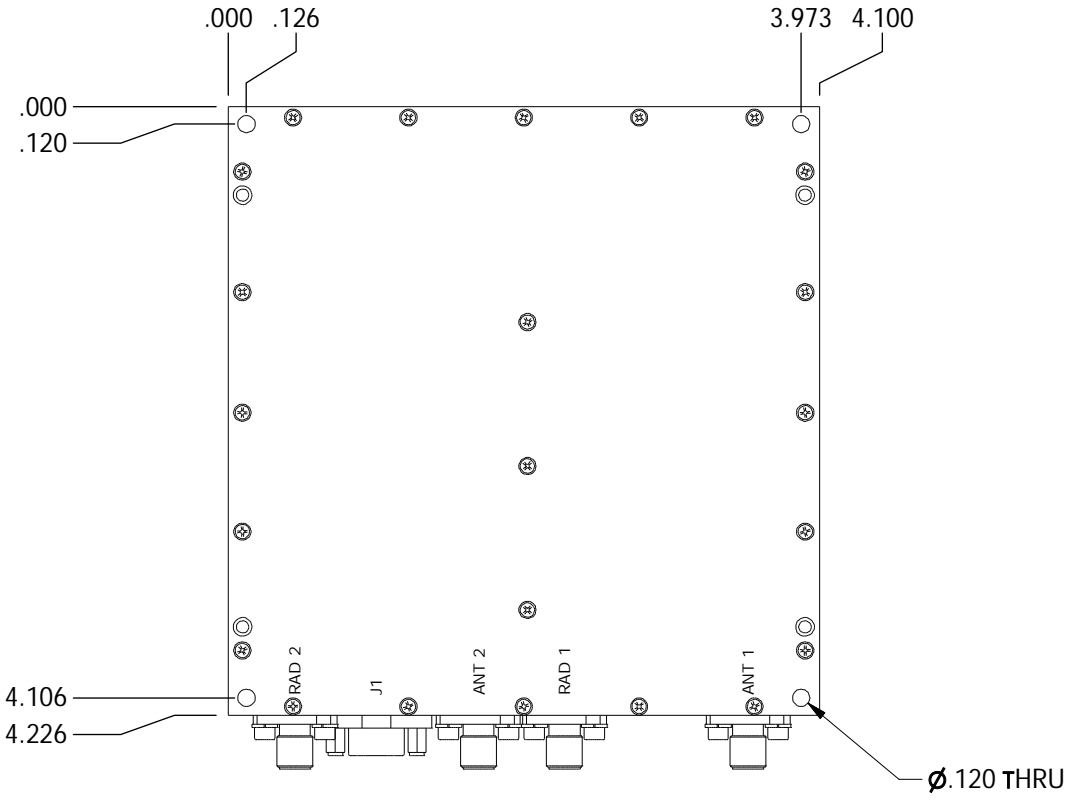

DRAWN	DMC	4/21/2014
DESIGNED	DH	4/21/2014
CHECKED		
ENG APPROVED		
MFG APPROVED		

TRIAD
RF SYSTEMS

180 TICES LANE
BUILDING A, SUITE 107
EAST BRUNSWICK, NJ 08816
855- 558- 1001

HOUSING OUTLINE DRAWING 132

DIMENSIONS ARE IN INCHES UNLESS SPECIFIED OTHERWISE TOLERANCES		SIZE	DWG NO.	REV
DECIMALS	FRACTIONS	ANGLES	A	0
XX ±.01	± 1/32	± 2°	OL_132	
.XXX ±.005			SCALE: NONE	CAGE CODE 67DZ3
			SHEET 1 OF 3	

A B C D E

1
2
3
4

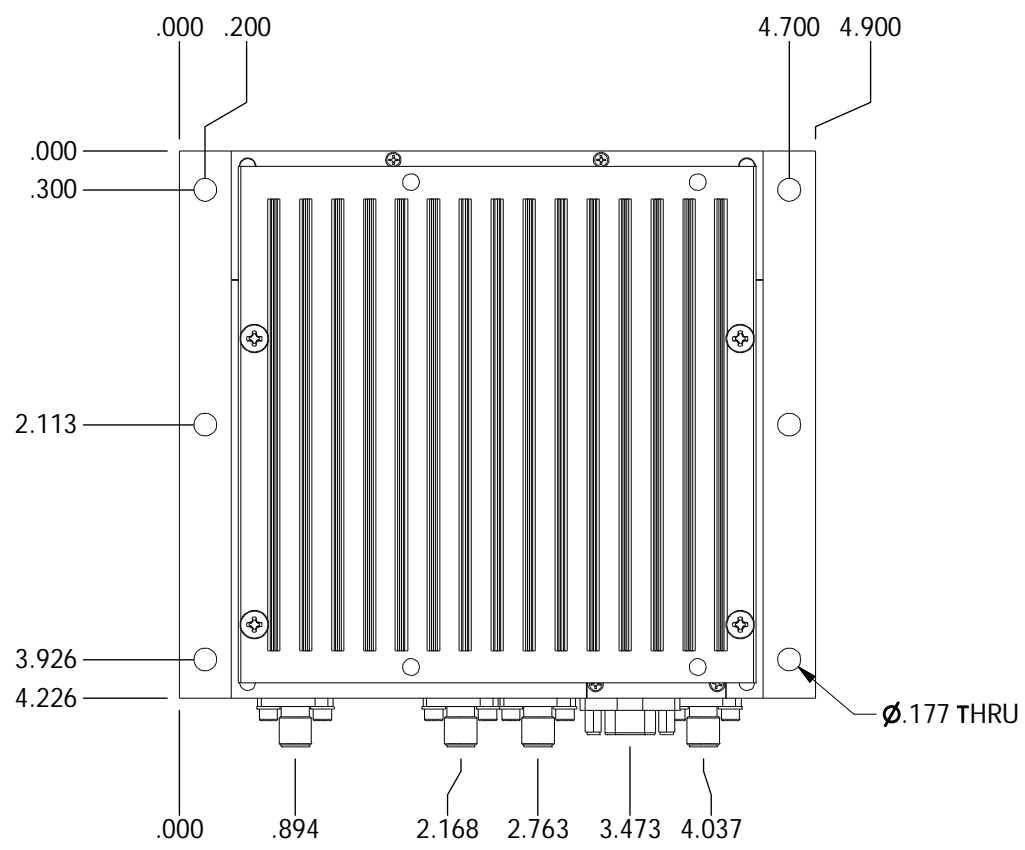

OPTIONAL HEATSINK

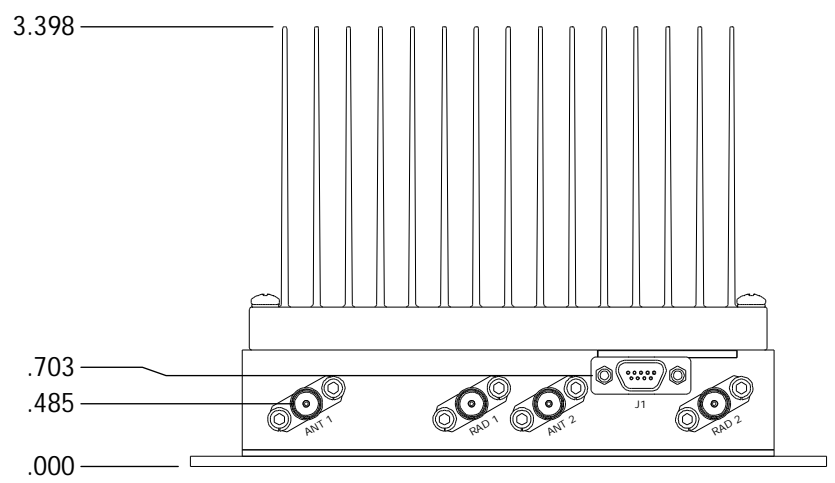
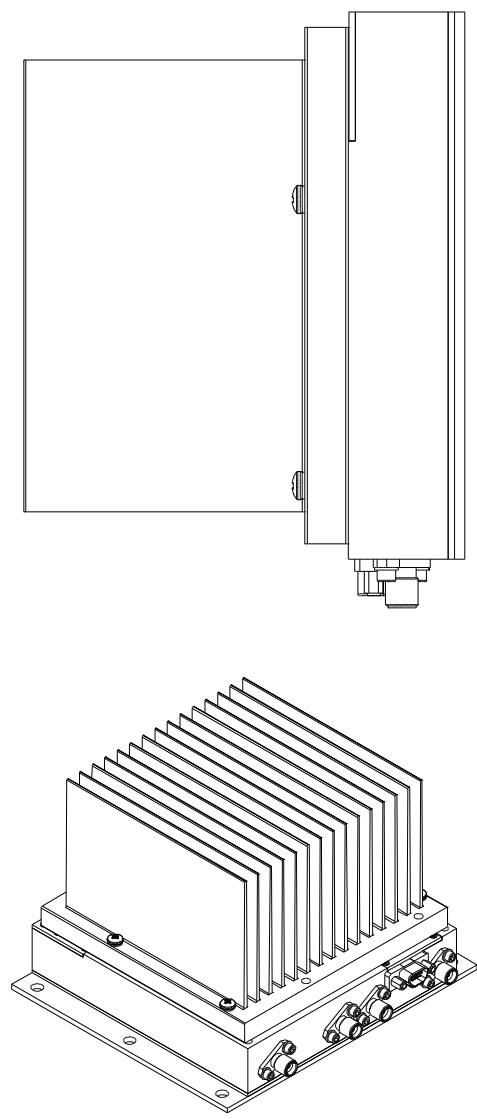

A B C D E

DRAWN	DMC	4/21/2014	HOUSING OUTLINE DRAWING 132		
DESIGNED	DH	4/21/2014	SIZE	DWG NO.	REV
CHECKED			A	OL_132	0
ENG APPROVED			SCALE: NONE	CAGE CODE	67DZ3
MFG APPROVED				SHEET	2 OF 3

A B C D E

LOW PROFILE HEATSINK

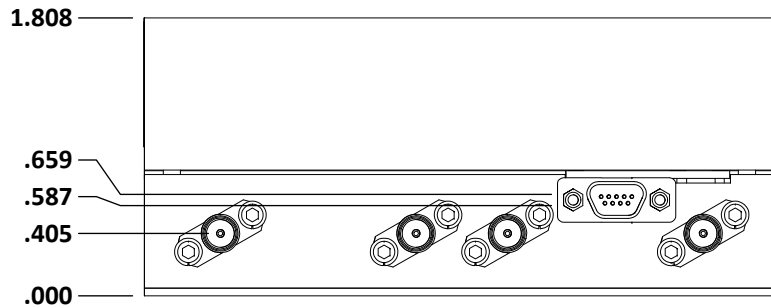
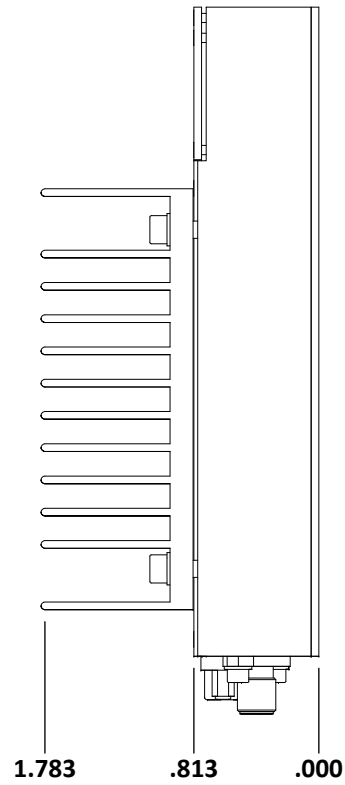
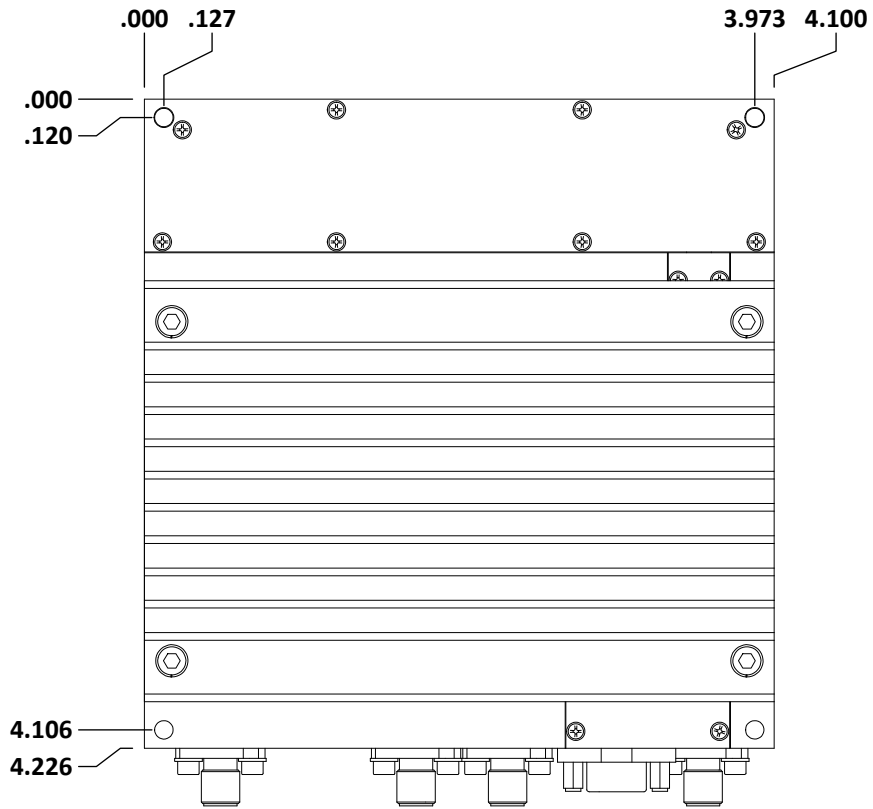

DRAWN	Dean	4/21/2014
DESIGNED	DH	4/21/2014
CHECKED		
ENG APPROVED		
MFG APPROVED		



11 Harts Lane,
EAST BRUNSWICK, NJ 08816
855-558-1001

DIMENSIONS ARE IN INCHES
UNLESS SPECIFIED OTHERWISE
TOLERANCES
DECIMALS FRACTIONS ANGLES
.XX ±.01 ±1/32 ±2°
.XXX ±.005

SIZE A	DWG NO. OL_132	REV 0
SCALE: NONE	CAGE CODE 67DZ3	SHEET 1 OF 1

A B C D E

J1 CONNECTOR DETAIL

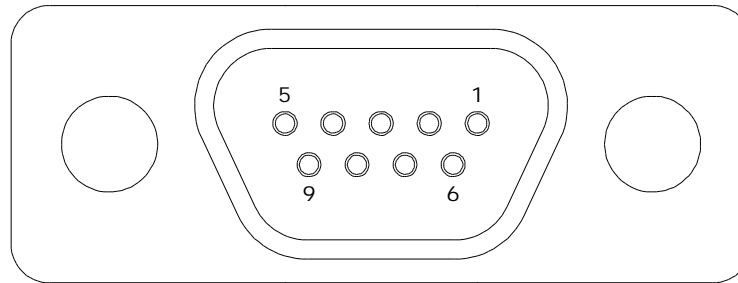

VIEW FACING CONNECTOR INTERFACE (AMP SIDE)

P/N OF CONNECTOR ON AMPLIFIER: ITT M83513/02-AC
P/N OF MATING CONNECTOR REQUIRED: ITT M83513/01-AC OR EQUIVALENT

CONNECTOR PINOUT		
PIN	FUNCTION	NOTES
1-2	+VDC	SUPPLY VOLTAGE - RANGE SPECIFIED IN DATA SHEET
5	TEMP	ANALOG TEMPERATURE SENSOR OUTPUT (VOLTAGE READ AT PIN - 0.5V) x 100 = AMPLIFIER TEMP in DEG C
6-7	GND	SUPPLY VOLTAGE RETURN
9	Tx/Rx CTRL	3.3V TTL LOGIC INPUT HIGH = SSPA IN TX MODE (LNA OFF, PA ON) LOW (OR NO CONNECTION) = SSPA IN RX MODE (LNA ON, PA OFF)

DRAWN	DMC	4/21/2014	HOUSING OUTLINE DRAWING 132		
DESIGNED	DH	12/12/2014	SIZE	DWG NO.	REV
CHECKED			A	OL_132	0
ENG APPROVED			SCALE: NONE	CAGE CODE	67DZ3
MFG APPROVED				SHEET	3 OF 3