

DESCRIPTION

This class AB GaN module is designed for both military and commercial applications. It is capable of supporting any signal type and modulation format, including but not limited to 3-4G telecom, WLAN, OFDM, DVB, and CW/AM/FM. The latest device technologies and design methods are employed to offer high power density, efficiency, and linearity in a small, lightweight package.



FEATURES

Over / Under / Reverse Voltage Protection
Optional Heatsink

High Speed On/Off Control

Specifications subject to change without notice. Typical performance at +12VDC +25°C, and in a 50Ω system.

RF / ELECTRICAL				
PARAMETER	MIN	TYP.	MAX	UNIT
Operating Frequency	2000		2200	MHz
PSat Power Output		+47.0		dBm
Gain	25.0	27.0		dB
Gain Flatness		1.0	1.5	dB ¹
Input Return Loss	-12	-16		dB
Operating Voltage	+10	+12	+28	VDC
Current Draw		9.0	10.0	A
Switching Time		1.0	2.0	uS

1 – Gain flatness recorded represents a peak-peak measurement across the **entire operating band**. Gain flatness is typically much lower across significant portions of this band. Consult the gain response plots for details if available.

MECHANICAL

PARAMETER	VALUE	UNIT
Dimensions (L x W x H)	4.93 x 2.53 x 0.7	in
RF Connectors (Input / Output)	SMA-F / SMA-F	--
DC / Control Connector	15 Pin Micro-D	--
Cooling	Baseplate Conduction - Optional Heatsink Available	--
Mounting	4-40 Thru Holes	--
Weight	4	oz.
Weight with Heatsink	7	oz.

ENVIRONMENTAL / PROTECTIONS

PARAMETER	MIN	MAX	UNIT
Operating Temp. (Housing Temp.)	-40	+85	°C
Humidity Range	0-100		%
Altitude	0-30,000		ft.
Shock / Vibration	MIL-STD-810 and equivalents		--
Max RF Input	+22		dBm
PA Baseplate Shutoff Temperature	+ 85		°C

INPUT/OUTPUT PINS

AMPLIFIER CONNECTOR TYPE:		15 PIN MICRO-D FEMALE
TRIAD CABLE PART NUMBER:		CBL63
PIN NUMBER	LABEL	DESCRIPTION
1,2,3,9,10	+VDC	Supply Voltage - Range Specified in Datasheet
7,8,14,15,13	GND	Ground
12	SIG GND	Signal Ground
4	FWD	Forward Power Detector
5	Amp Enable	TTL Hi or No Connection = Enable, TTL Lo = Disable
6	TEMP	Temp Monitor: Temp in DegC = (Vout - 0.5V) * 100
11	N/C	No Connection

Configuration Options

Model Number	Description
TA1105	No Heat Sink Included
TA1105 – HS	Standard Heat Sink
TA1105 – HSF	Heat Sink with Integrated Cooling Fan
TA1105 – HSX	Custom Heat Sink Configuration
TA1105 – DOX	Custom Amplifier Configuration (issued by Triad upon customer request)

REVISIONS			
REV	DESCRIPTION	DATE	APPROVED
0	INITIAL RELEASE	5/9/18	SC
1	E18351	8/17/18	SC

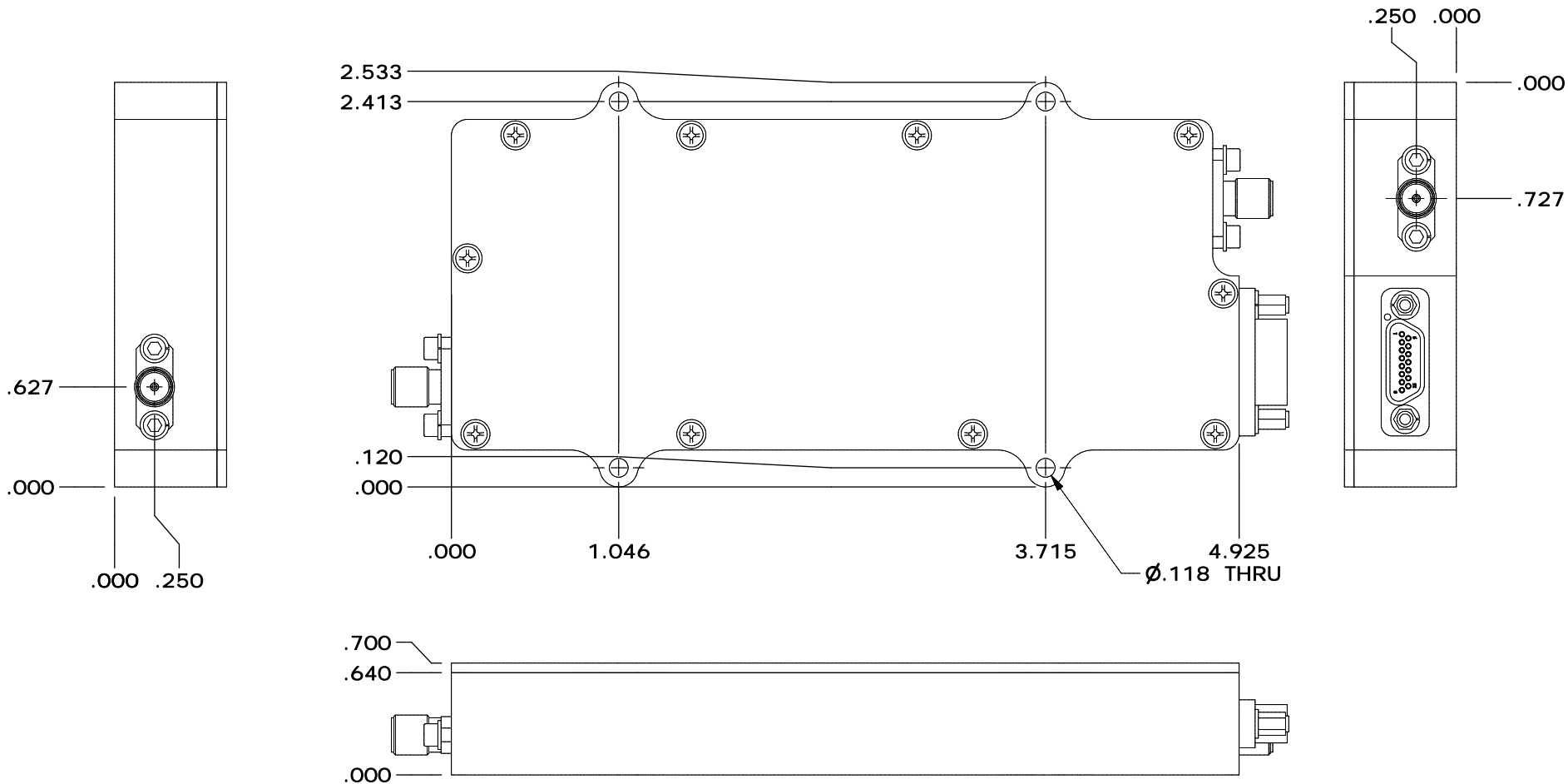

CONNECTOR ON AMPLIFIER: ITT CANNON MDM-15SH034B

MATING CONNECTOR: ITT CANNON MDM-15PH006B-F222

DRAWN	scopp	10/3/2013
DESIGNED	scopp	5/7/2018
CHECKED	SC	5/9/2018
ENG APPROVED		
MFG APPROVED		

DIMENSIONS ARE IN INCHES
UNLESS SPECIFIED OTHERWISE
TOLERANCES
DECIMALS FRACTIONS ANGLES
XX ±.01 ± 1/32 ± 2°
.XXX ±.005



11 HARTS LANE SUITE 1
EAST BRUNSWICK, NJ 08816
855- 558- 1001

HOUSING OUTLINE DRAWING 192

SIZE	DWG NO.	REV
A	OL_192	1
SCALE: NONE	CAGE CODE 67DZ3	SHEET 1 OF 3

OPTIONAL HEATSINK

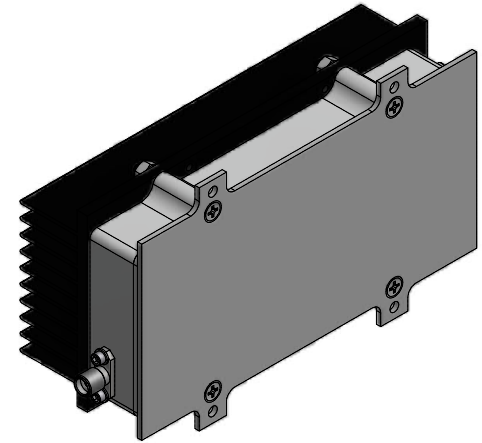
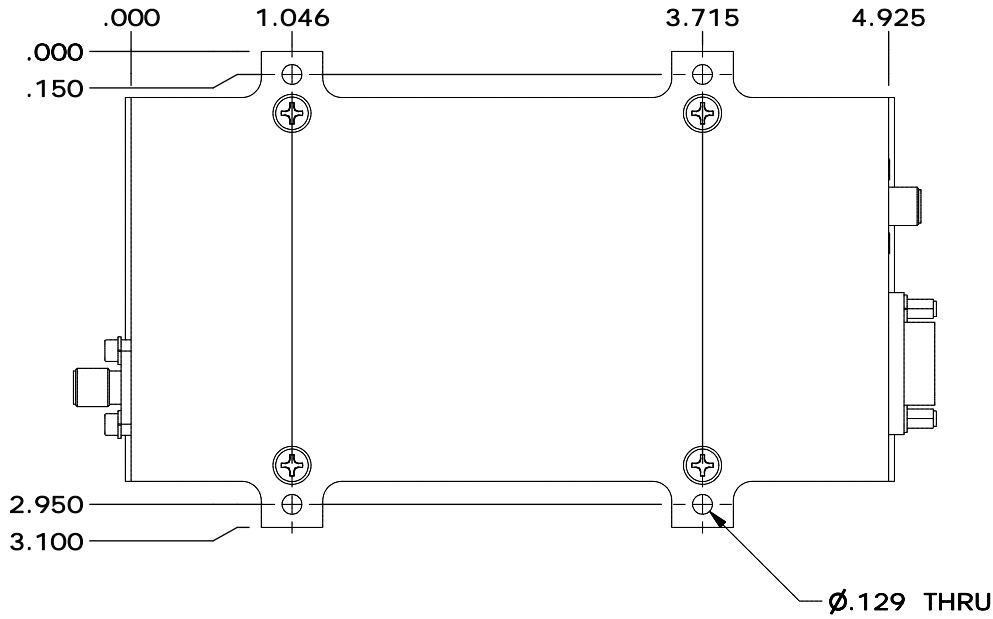
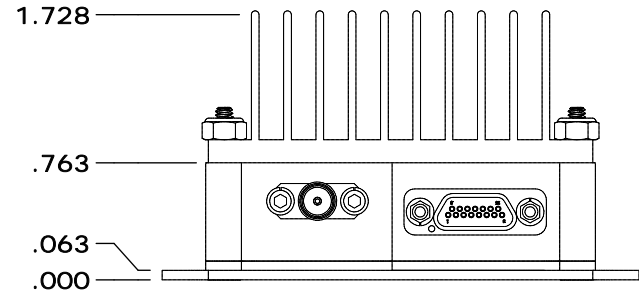
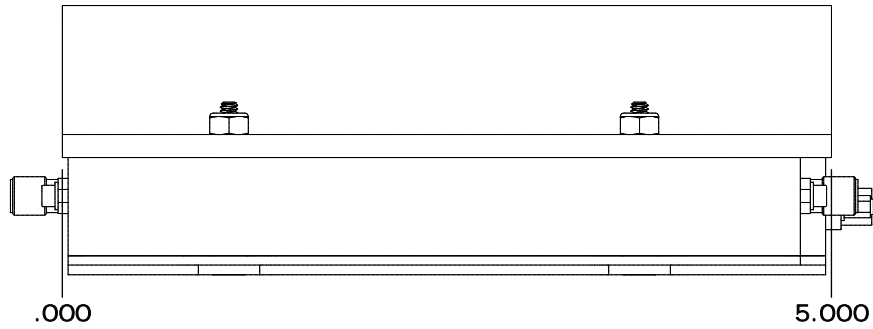

DRAWN	scopp	10/3/2013	HOUSING OUTLINE DRAWING 192		
DESIGNED	scopp	5/7/2018	SIZE	DWG NO.	REV
CHECKED	SC	5/9/2018	A	OL_192	1
ENG APPROVED			SCALE: NONE	CAGE CODE 67DZ3	SHEET 2 OF 3
MFG APPROVED					

OPTIONAL HEATSINK AND COOLING FAN

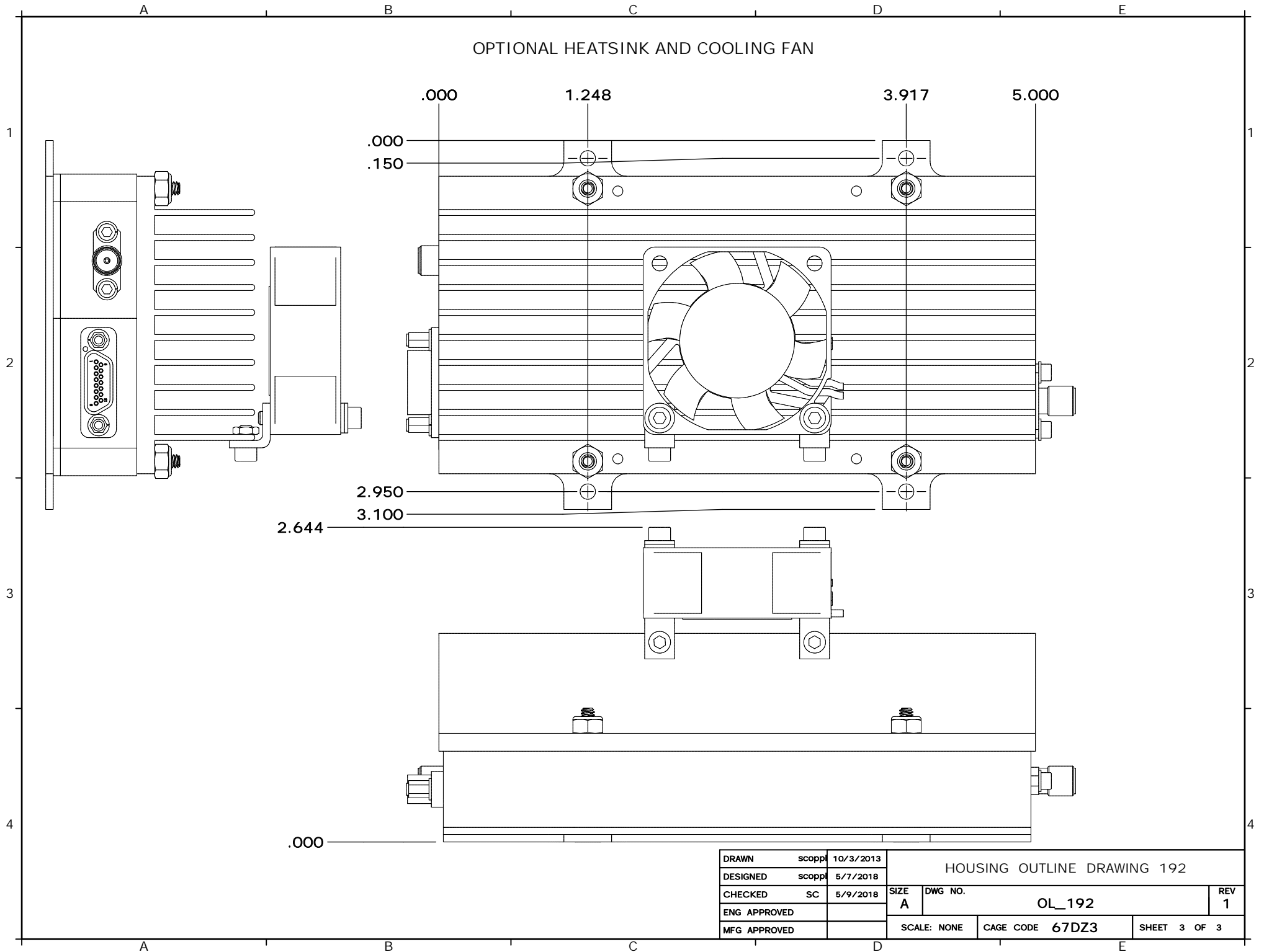

DRAWN	scopp	10/3/2013
DESIGNED	scopp	5/7/2018
CHECKED	SC	5/9/2018
ENG APPROVED		
MFG APPROVED		

HOUSING OUTLINE DRAWING 192

SIZE	DWG NO.	REV
A	OL_192	1

SCALE: NONE CAGE CODE 67DZ3 SHEET 3 OF 3